



SYSTEMS S3000

INDUSTRIAL CONTROLLER

S3080: ANALOG I/O BOARD 4 ANALOG INPUTS AND 4 ANALOG OUTPUTS

FEATURES:

- 4 SINGLE ENDED ANALOG INPUT POINTS AND 4 SINGLE ENDED ANALOG OUTPUT POINTS
- 12-BIT, UNIPOLAR ANALOG-TO-DIGITAL CONVERSION ON INPUT POINTS
- 12-BIT, UNIPOLAR DIGITAL-TO-ANALOG CONVERSION ON OUTPUT POINTS
- INPUTS INDIVIDUALLY SELECTABLE FOR 0-5V, 0-10V, AND 0-20mA INPUT RANGES
- OUTPUTS INDIVIDUALLY SELECTABLE FOR 0-5V, 0-10V, AND 0-20mA OUTPUT RANGES
- FAST CONVERSION TIMES: 0.2 MILLISECONDS PER INPUT POINT AND 0.2 MILLISECONDS PER OUTPUT POINT
- STATUS AND POWER LEDS TO INDICATE PROPER OPERATION OF BOARD
- HIGH ISOLATION VOLTAGE BETWEEN ANALOG I/O SECTION AND S3000 BUS
- REMOVABLE FIELD WIRING CONNECTORS

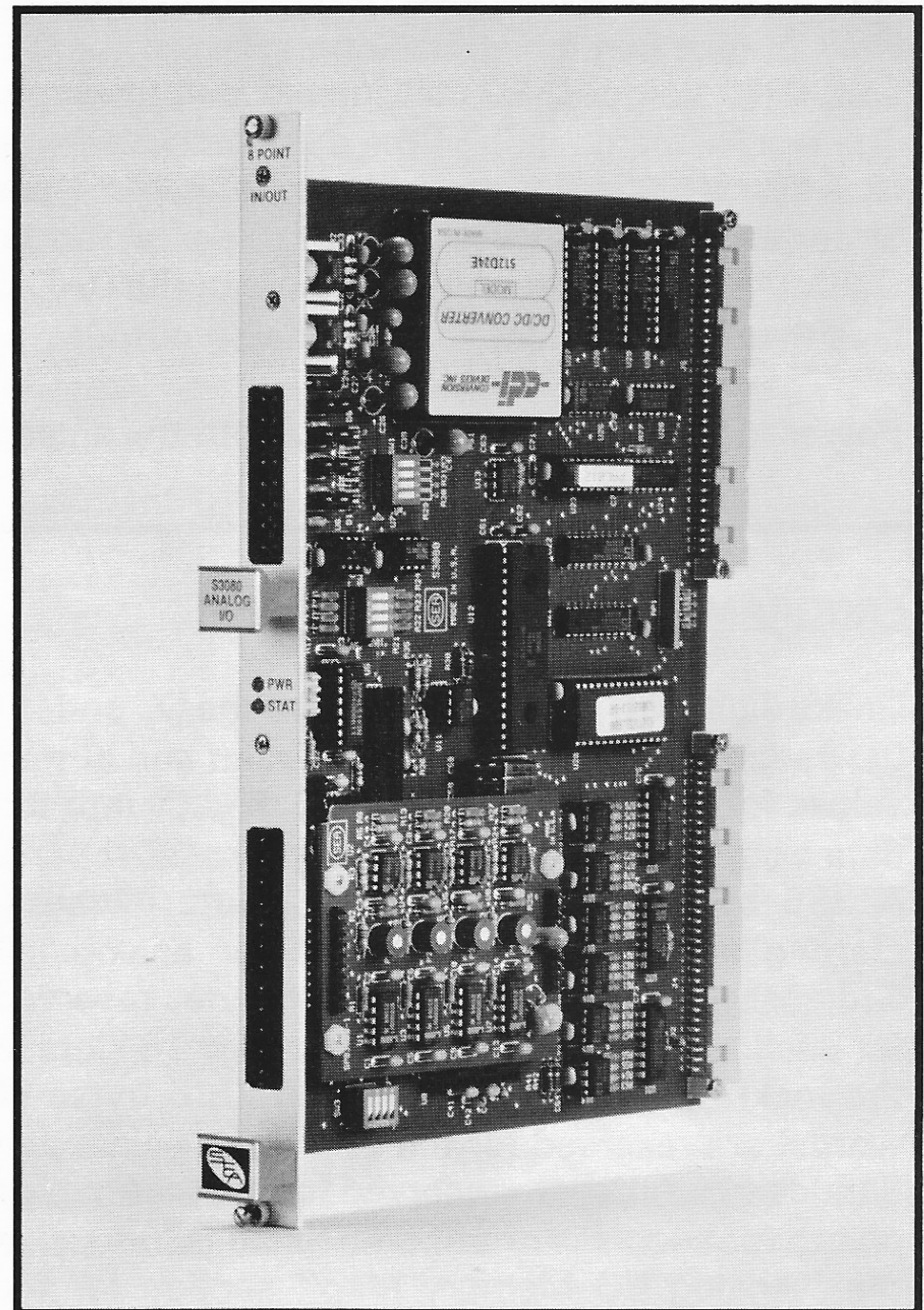

- STANDARD SINGLE WIDTH DOUBLE HEIGHT EUROCARD

GENERAL DESCRIPTION:

The S3080 Analog I/O board contains 4 analog inputs and 4 analog outputs on one single width board. The analog inputs are converted to digital values which can then be read by the main processor board of the system. The main processor writes digital values, to the S3080, for each output point which are then converted to the corresponding analog value.

The input section consists of four single ended analog inputs which are multiplexed to one analog-to-digital converter (ADC). The ADC converts the

analog value for each input, one at a time, to the corresponding digital value. The ADC is a 12-bit, unipolar successive approximation converter with a full range of 0 to 4095 decimal. Each input can individually be selected for 0-5 volt, 0-10 volt or 0-20 milliamper input range. The resolution for each of the three input ranges is: 1.22mV per bit for the 0-5V range, 2.44mV per bit for the 0-10V range, and 4.88uA per bit for the 0-20mA range.

The conversion time of the ADC is less than 0.2 milliseconds per analog input.

GENERAL DESCRIPTION (cont'd):

The output section consists of four single ended analog outputs, each equipped with its own digital-to-analog converter (DAC). Each DAC converts the corresponding digital value for the output to an analog value representing the digital value. The DACs are 12-bit, unipolar digital-to-analog converters with a full range of 0 to 4095 decimal. Each output can individually be selected for 0-5 volt, 0-10 volt or 0-20 milliampere output range. The resolution for each of the three output ranges is: 1.22mV per bit for the 0-5V range, 2.44mV per bit for the 0-10V range, and 4.88uA per bit for the 0-20mA range. The conversion time of the DAC is less than 0.2 milliseconds per analog output.

Power for the analog I/O section, both the analog

inputs and analog outputs, is derived from one +24VDC power source supplied by the user. The analog I/O section is electrically isolated, up to 1500V, from the S3000 bus.

The S3080 contains two LEDs on the faceplate: Status and Power. The Status LED is "on" when the S3080 is functioning properly, updating the analog inputs and analog outputs. The Power LED is "on" when the user +24VDC power is applied to the S3080.

Input, output, and user power wiring is implemented with removable field wiring connectors which allow easy board replacement. Refer to figure 2 for typical field wiring connections.

PROGRAM INTERFACE:

Unlike digital I/O boards, which use the 'X' and 'Y' I/O variables for addressing, the input and output values for the S3080 are mapped directly into the data memory of the S3012 main processor board. A 256 byte block in the S3012 data memory, starting at W7000, is reserved for analog I/O addressing with a maximum of 16 bytes reserved for each slot of the rack (maximum of 16 slots in the rack). In the case of the S3080, 8 bytes (4 words) are reserved for the four input points and 8 bytes (4 words) are reserved for the four output points for each slot that contains an S3080. See the "Analog I/O Memory Map" section for the mapping of these analog I/O points into the S3012 data memory.

The values for the S3080 analog input points are automatically read during the normal I/O update of the main program scan of the S3012 and stored in the data memory 'W' variables corresponding to the slot the S3080 resides in. Likewise, the values contained in the 'W' variables corresponding to the respective S3080 output points, are automatically written to the S3080 during the normal I/O update of the main program scan. These 'W' variables are referenced and/or altered in the user program just as any other 'W' variables are referenced.

The 'W' variables, corresponding to the input points, will contain a value between 0 and 4095 proportional to the analog value (voltage or cur-

rent, whichever is selected) of the respective analog input. To write a value to an analog output point, simply write 0 to 4095 to the 'W' variable that corresponds to the analog output point at the respective slot. The value of the analog output (voltage or current, whichever is selected) will be proportional to the value written to the corresponding 'W' variable. Note that the S3080 does not perform any scaling.

The analog I/O 'W' variables are only reserved as analog input or output variables for slots specified as containing S3080s in the system configuration. The 'W' variables for slots which do not contain S3080s are available for general use just as any other 'W' variables are. For example, if slot 6 was the only slot configured with an S3080, the following variables would then be reserved as analog I/O variables:

W7096:	Slot6-Input0
W7098:	Slot6-Input1
W7100:	Slot6-Input2
W7102:	Slot6-Input3
W7104:	Slot6-Output0
W7106:	Slot6-Output1
W7108:	Slot6-Output2
W7110:	Slot6-Output3

The remaining 'W' variables between W7000 and W7254 would be available for general use.

ANALOG I/O MEMORY MAP:

The S3080 analog I/O points are mapped into the S3012 main processor data memory as shown:

I/O	Address	I/O	Address	I/O	Address	I/O	Address
<u>Slot 0</u>		<u>Slot 4</u>		<u>Slot 8</u>		<u>Slot 12</u>	
Input 0:	W7000	Input 0:	W7064	Input 0:	W7128	Input 0:	W7192
Input 1:	W7002	Input 1:	W7066	Input 1:	W7130	Input 1:	W7194
Input 2:	W7004	Input 2:	W7068	Input 2:	W7132	Input 2:	W7196
Input 3:	W7006	Input 3:	W7070	Input 3:	W7134	Input 3:	W7198
Output 0:	W7008	Output 0:	W7072	Output 0:	W7136	Output 0:	W7200
Output 1:	W7010	Output 1:	W7074	Output 1:	W7138	Output 1:	W7202
Output 2:	W7012	Output 2:	W7076	Output 2:	W7140	Output 2:	W7204
Output 3:	W7014	Output 3:	W7078	Output 3:	W7142	Output 3:	W7206
<u>Slot 1</u>		<u>Slot 5</u>		<u>Slot 9</u>		<u>Slot 13</u>	
Input 0:	W7016	Input 0:	W7080	Input 0:	W7144	Input 0:	W7208
Input 1:	W7018	Input 1:	W7082	Input 1:	W7146	Input 1:	W7210
Input 2:	W7020	Input 2:	W7084	Input 2:	W7148	Input 2:	W7212
Input 3:	W7022	Input 3:	W7086	Input 3:	W7150	Input 3:	W7214
Output 0:	W7024	Output 0:	W7088	Output 0:	W7152	Output 0:	W7216
Output 1:	W7026	Output 1:	W7090	Output 1:	W7154	Output 1:	W7218
Output 2:	W7028	Output 2:	W7092	Output 2:	W7156	Output 2:	W7220
Output 3:	W7030	Output 3:	W7094	Output 3:	W7158	Output 3:	W7222
<u>Slot 2</u>		<u>Slot 6</u>		<u>Slot 10</u>		<u>Slot 14</u>	
Input 0:	W7032	Input 0:	W7096	Input 0:	W7160	Input 0:	W7224
Input 1:	W7034	Input 1:	W7098	Input 1:	W7162	Input 1:	W7226
Input 2:	W7036	Input 2:	W7100	Input 2:	W7164	Input 2:	W7228
Input 3:	W7038	Input 3:	W7102	Input 3:	W7166	Input 3:	W7230
Output 0:	W7040	Output 0:	W7104	Output 0:	W7168	Output 0:	W7232
Output 1:	W7042	Output 1:	W7106	Output 1:	W7170	Output 1:	W7234
Output 2:	W7044	Output 2:	W7108	Output 2:	W7172	Output 2:	W7236
Output 3:	W7046	Output 3:	W7110	Output 3:	W7174	Output 3:	W7238
<u>Slot 3</u>		<u>Slot 7</u>		<u>Slot 11</u>		<u>Slot 15</u>	
Input 0:	W7048	Input 0:	W7112	Input 0:	W7176	Input 0:	W7240
Input 1:	W7050	Input 1:	W7114	Input 1:	W7178	Input 1:	W7242
Input 2:	W7052	Input 2:	W7116	Input 2:	W7180	Input 2:	W7244
Input 3:	W7054	Input 3:	W7118	Input 3:	W7182	Input 3:	W7246
Output 0:	W7056	Output 0:	W7120	Output 0:	W7184	Output 0:	W7248
Output 1:	W7058	Output 1:	W7122	Output 1:	W7186	Output 1:	W7250
Output 2:	W7060	Output 2:	W7124	Output 2:	W7188	Output 2:	W7252
Output 3:	W7062	Output 3:	W7126	Output 3:	W7190	Output 3:	W7254

INSTALLATION:

The S3080 may be installed in any I/O slot of the S3000 rack, provided the main processor of the rack is configured to address that slot as an S3080. Prior to installing the S3080, the input and output range selection dip switches must be set for the desired ranges and types. To install the S3080, perform the following:

- 1) Set the input "mA/V" dip switches for each input to either the "mA" position for 0-20mA range or to the "V" position for either the 0-5V or 0-10V range (see figure 1).
- 2) For inputs selected as "V" in the previous step, set the input "5V/10V" dip switches to either the "5V" position for the 0-5V range or the "10V" position for the 0-10V range (see figure 1).
- 3) For inputs selected as "mA" in step (1), set the input "5V/10V" dip switches to the "5V" position (see figure 1).
- 4) For outputs used in the 0-5V or 0-10V range, set the output "5V/10V" dip switches to the "5V" position for the 0-5V range or to the "10V" position for the 0-10V range. The output "5V/10V" dip switches can be in either position if the 0-20mA output is used.
- 5) Install the S3080 in the rack by aligning the board with the card guides and sliding in until firmly seated. The board is held in the rack via captive screws located on the S3080 faceplate.
- 6) Install the field wiring connectors in the S3080, making sure the connectors are properly mated in the field wiring receptacles. Refer to figure 2 for typical field wiring connections. Note that each analog output has a separate terminal for the 0-5V/0-10V output and the 0-20mA output.
- 7) To remove the S3080, remove the field wiring connectors and loosen the captive screws holding the board in the rack. Gently pull the board out of the rack using the handles located on the faceplate.

Note: When installing or removing the S3080, the S3000 rack power must be "off".

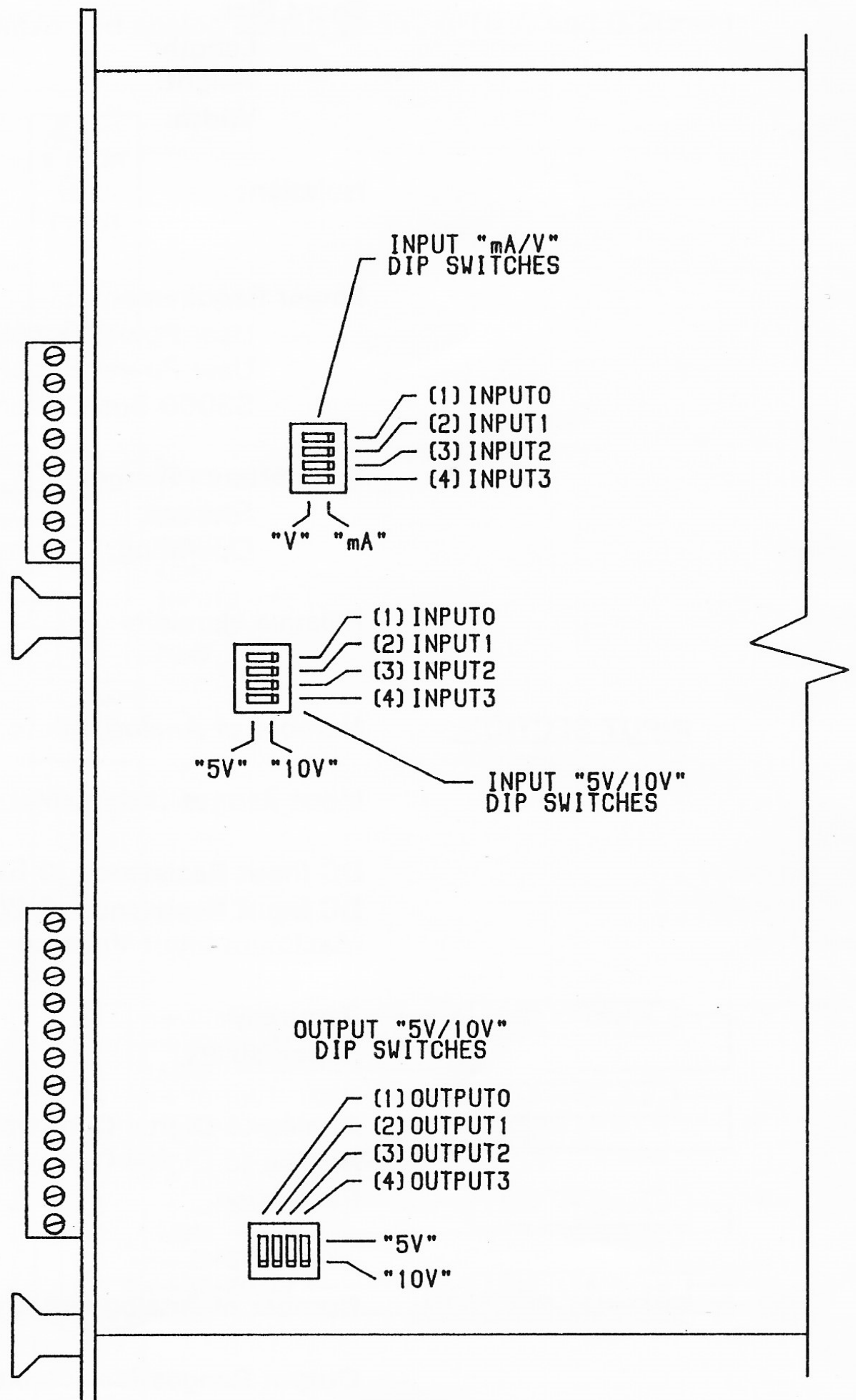

FIGURE 1
Board Outline

NOTE: FOR THE ABOVE DIP SWITCHES, DEPRESSING THE SWITCH DOWN ON A SPECIFIC SIDE, SELECTS THE CORRESPONDING FUNCTION OF THE SWITCH.

SPECIFICATIONS:

Number Of I/O Slots Required:	1
Board Size:	
Length:	9.15"
Height:	6.30"
Width:	0.80"
Isolation:	1500V Analog I/O section to S3000 bus
Power Requirements:	
User Power Supply Voltage:	24VDC +-10%
User Power Supply Current:	0.5 Amps (max)
S3000 Bus Current:	0.5 Amps (max)
Temperature Ranges:	
Storage:	0 to 85 degrees C
Operating:	0 to 60 degrees C
Relative Humidity:	5 to 95%

INPUT SECTION:

Number of Analog Inputs:	4
Input Ranges (selectable):	0-5 Volt, 0-10 Volt, 0-20 mA
DC Input Resistance (0-5V/0-10V):	1M ohms or greater
DC Input Resistance (0-20mA):	250 ohms
Maximum Input Voltage:	+ -30 Volts
Accuracy:	0.5%
Repeatability:	0.1%
Analog-to-Digital Conversion Method:	Successive Approximation
Analog-to-Digital Conversion Time:	0.2 milliseconds per point
Resolution:	12-bit

OUTPUT SECTION:

Number of Analog Outputs:	4
Output Ranges (selectable):	0-5 Volt, 0-10 Volt, 0-20 mA
Load Resistance (0-5V/0-10V):	2K ohms or greater
Load Resistance (0-20mA):	400 ohms or less
Accuracy (0-5V/0-10v):	0.5%
Accuracy (0-20mA):	0.75%
Digital-to-Analog Conversion time:	0.2 milliseconds per point
Resolution:	12-bit
Short Circuit Duration (0-5V/0-10V):	continuous
Short Circuit Duration (0-20mA):	continuous

WIRING:

Typical analog input (0-5V, 0-10V, and 0-20mA) and analog output (0-5V, 0-10V, and 0-20mA) connections. Reference Figure 2.

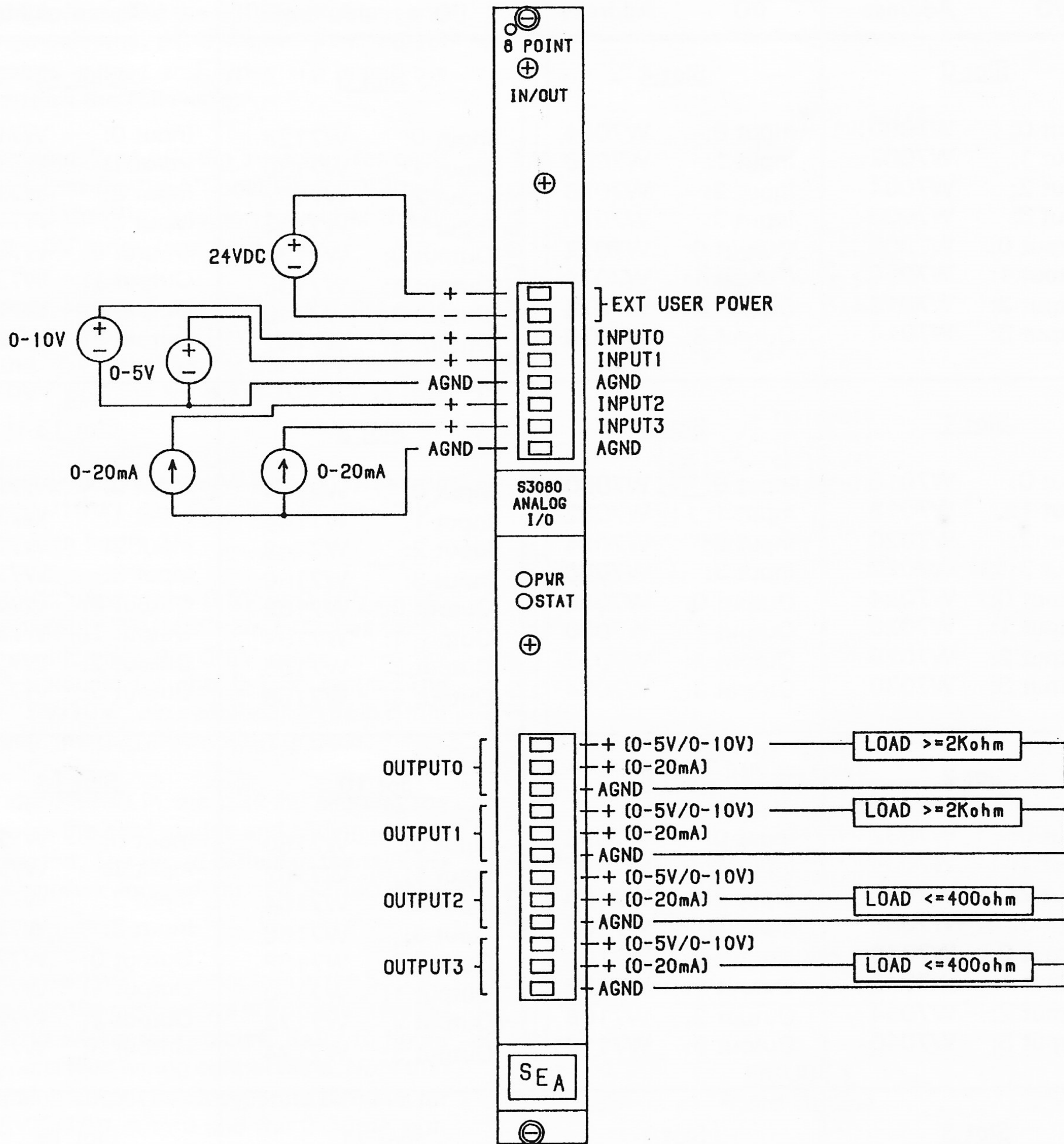

FIGURE 2



SYSTEMS ELECTRONICS GROUP

DIVISION OF SYSTEMS ENGINEERING ASSOCIATES, INC.
 14989 W. 69TH AVE, ARVADA, COLORADO, P.O. BOX 750 80001
 (303) 421-0233 FAX (303) 421-8108